

AquaCal® Installation Manual

HEATWAVE SUPERQUIET®



Important

Read this document before operating / installing this product

For additional product manuals and operation / installation procedures, please visit www.AquaCal.com

[-----]

MODEL / SERIAL NUMBER

Table of Contents

Contacting AquaCal AutoPilot, Inc.	1
Safety Instructions	1
1 - Installation	3
1.1 Positioning Equipment	3
1.2 Clearances	4
1.3 Dimensions	5
1.4 Plumbing	5
1.4.a Plumbing Requirements	5
1.4.b Plumbing Diagrams	6
1.4.c Water Connections to Heat Pump	8
1.4.d In-Line Chlorine Feeders	9
1.4.e Water Flow Rates	10
1.4.f Adjusting Water Flow Using ΔT (Delta-T)	11
1.4.g Maintaining Ability to Winterize	12
1.4.h Adjusting Water Pressure Switch	12
1.5 Electrical	13
1.5.a Electrical Requirements	13
1.5.b Incoming Power Access Holes	16
1.5.c Access Panels	17
1.5.d Verifying Transformer Setting	17
1.5.e Three-Phase Adjustment	18
1.5.f Schematics	18
1.5.g Connecting an External Controller	18
1.5.h Programming for an External Controller	20
1.6 Service Level Programming	21
1.6.a Service Level Factory Defaults	22
1.6.b Enter Service Level Programming	23
1.7 Cleaning Equipment After Installation	24
2 - Appendix	26
2.1 Identifying Model Specifications	26
2.2 Weights	27
2.3 Heating Recommendations	27
2.4 Cooling Recommendations	27
2.5 Available Accessories	28
3 - Troubleshooting	31
3.1 Fault Codes	31
3.2 Issues and Resolutions	34

Contacting AquaCal AutoPilot, Inc.

For further assistance, please contact the distributor or installer of this product.

If unavailable, please contact AquaCal® for a partner in your area. To better assist you, please have the heat pump model and serial number available.



- See "Identifying Model Specifications" on page 26.

Product Information:	
Website	www.AquaCal.com
Phone	(1) 727-823-5642
Hours	8-5 pm, Eastern M-F

SAFETY INSTRUCTIONS

- For personal safety, and to avoid damage to equipment, follow all safety instructions displayed on the equipment and within this manual. Repair and service of heat pump must be performed by an authorized service center.
- Warranties may be voided if the equipment has been improperly installed, maintained or serviced.
- If service is deemed necessary, please see "Contacting AquaCal AutoPilot, Inc." on page 1.

SAFETY SIGNALS
Throughout this document, safety signals have been placed where particular attention is required.

	Failure to heed the following will result in injury or death.
	Failure to heed the following may result in injury or death.
	Failure to heed the following may result in damage to equipment.

When installing and using your heat pump basic safety precautions must always be followed, including the following:

 Failure to heed the following will result in injury or death.

- The heat pump utilizes high voltage and rotating equipment. Use caution when servicing.



Failure to heed the following may result in injury or death.

- Installation and repairs must be performed by a qualified technician.
- The heat pump contains refrigerant under pressure. Repairs to the refrigerant circuit must not be attempted by untrained and / or unqualified individuals. Service must be performed only by qualified HVAC technicians. Recover refrigerant before opening the system.
- Improper water chemistry can present a serious health hazard. To avoid possible hazards, maintain pool / spa water per standards detailed in this document.
- Prolonged immersion in water warmer than normal body temperature may cause a condition known as Hyperthermia. The symptoms of Hyperthermia include unawareness of impending hazard, failure to perceive heat, failure to recognize the need to exit the spa, and unconsciousness. The use of alcohol, drugs, or medication can greatly increase the risk of fatal Hyperthermia. In addition, persons having an adverse medical history, or pregnant women, should consult a physician before using a hot tub or spa. Children and the elderly should be supervised by a responsible adult.
- Prolonged immersion in water colder than normal body temperature may cause a condition known as Hypothermia. The symptoms of Hypothermia include shivering (although as hypothermia worsens, shivering stops), clumsiness or lack of coordination, slurred speech or mumbling, confusion and poor decision-making, drowsiness or low energy, lack of concern about personal welfare, progressive loss of consciousness, weak pulse and slow or shallow breathing. In addition, persons having an adverse medical history, or pregnant women, should consult a physician before immersing in a cold body of water. Children and the elderly should be supervised by a responsible adult.



Failure to heed the following may result in damage to equipment.

- Maintain proper water chemistry in order to avoid damage to pump, filter, pool shell, etc.
- Water flow exceeding maximum flow rate requires a bypass. Damage due to excessive water flow will void warranty.

SAVE THESE INSTRUCTIONS

1 - Installation

WARNING

Failure to heed the following may result in injury or death.

- Installation of this equipment by anyone other than a qualified installer can result in a safety hazard.
- The information contained throughout the "Installation" section is intended for use by qualified installation technicians familiar with the swimming Pool / Spa safety standards.

NOTICE

Failure to heed the following may result in damage to equipment.

- Failure to protect equipment against corrosive conditions will adversely affect the life of the equipment and will void equipment warranty.

1.1 Positioning Equipment

NOTICE

Failure to heed the following may result in damage to equipment.

- Do not install equipment inside of a building.

Outdoor Use Only

Do not install equipment inside of a room or building.

- Heat Pumps require unobstructed air flow for proper operation. Heat Pumps should never be installed indoors or in a location where air flow is restricted. See "Clearances" on page 4.

Controlling Irrigation and Rainwater Runoff

- Irrigation water may damage heat pump components. Direct irrigation water away from the heat pump.
- The heat pump will withstand normal rainfall. Do not allow a roof slope to direct rainwater onto the heat pump. Have a gutter installed on the roof edge to direct this water away from the heat pump. Or install the heat pump in another location.

Planning for Condensation

The heat pump can produce a large amount of condensation. The amount of water depends on air temperature and humidity.

- Install the heat pump with enough height to allow for water drainage.
- Plan for water drainage as needed.
 - See "Condensation Drain Kit (# STK0202)" on page 28.

Mounting Pad Requirements

- The heat pump's base must be installed on a flat and level surface that completely supports the entire base.
- Build the heat pump pad out of concrete or other code-approved material.
- Confirm the pad can support the weight of the heat pump. See "Weights" on page 27.
- Elevate the pad enough to allow for drainage.
- Make sure the pad is flat and level.
- Have the pad extend at least 6 inches from the heat pump base in all directions.
- Do not install the heat pump on soil or grass.
- Do not allow the heat pump base to touch the building's foundation.
- Do not place the heat pump directly on a concrete floor. This can cause noise to be transmitted to an occupied space. If necessary install vibration dampers between the heat pump base and floor.
- Equipment pad must meet all requirements of authorities having code-related jurisdiction.

Anchoring to Pad

- Follow all applicable local, state, and national requirements regarding wind load anchoring.
- The shipping brackets used to secure the heat pump to the pallet are approved mounting (hurricane) brackets. They should be used to anchor the heat pump to the pad.
- If needed, contact AquaCal® to obtain anchoring kit information. Please have the heat pump model number and serial number when requesting support. See "Identifying Model Specifications" on page 26.

1.2 Clearances

- Proper air circulation is required for the heat pump to operate efficiently. The following diagrams show the minimum clearances required for the proper operation of the heat pump.
- Avoid storing chemical containers near the heat pump. The chemicals can cause equipment damage.
- Avoid placing objects near or on top of the heat pump. This includes shrubbery and lawn furniture. These objects will reduce performance and efficiency and hinder maintenance access.

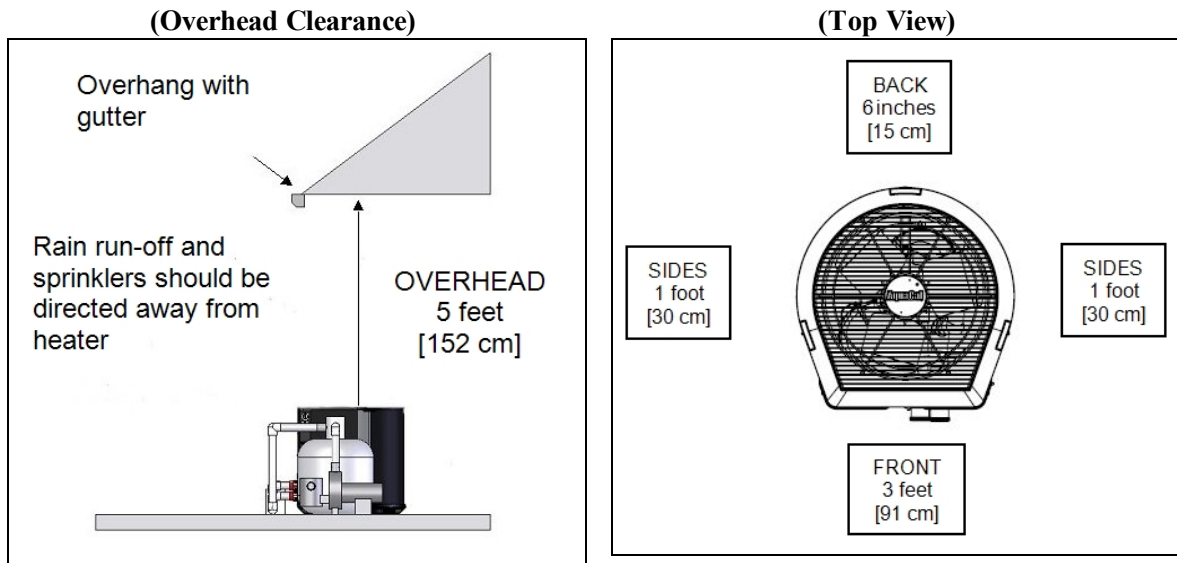

1.3 Dimensions

(HeatWave SuperQuiet® SQ120R, SQ125, SQ145, SQ166R and SQ225)

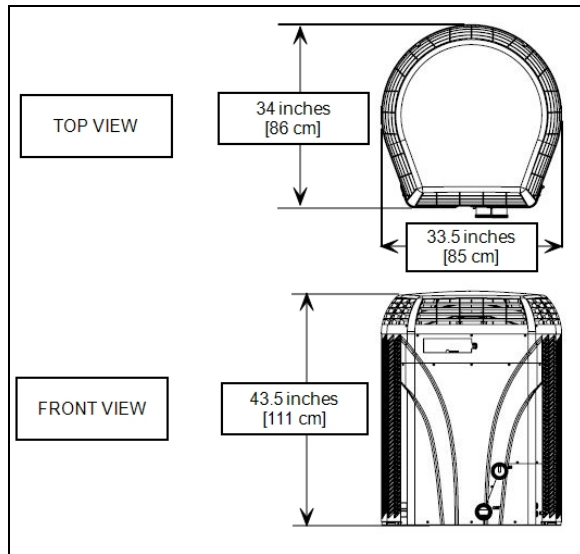

(TropiCal® T035, T055 and T075)

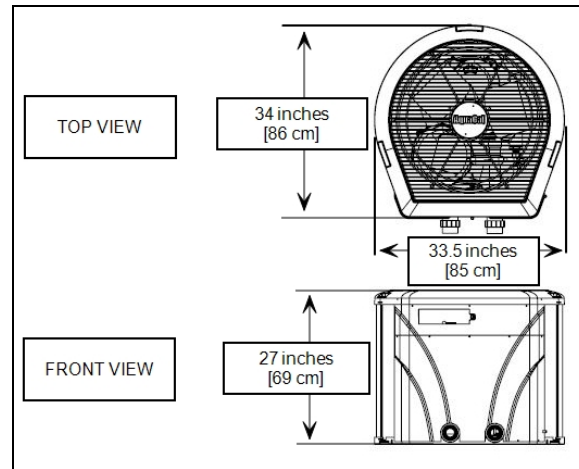

(TropiCal® T090, T115 and T135)

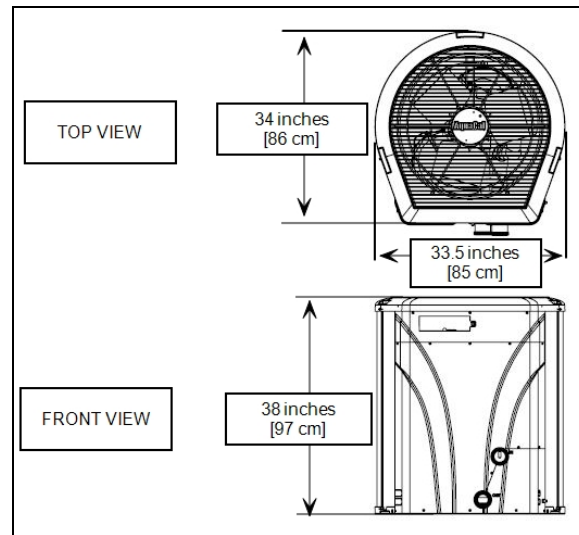

1.4 Plumbing

1.4.a Plumbing Requirements

NOTICE

Failure to heed the following may result in damage to equipment.

- Do not use glue on the threaded portion of the equipment's unions. A glued-in-place union will prevent the equipment from being properly winterized.
- The heat pump must receive water flow within the specified minimum ranges under worst-case conditions such as a fouled water filter.
- Failure to provide clean filtered water to the heat pump can void product warranty.
- Water flow exceeding maximum flow rates will negatively affect the total pool filtration performance and may damage the heat pump. This will not be covered under equipment warranty. See "Water Flow Rates" on page 10.
 - Install a bypass valve whenever water-flow may exceed maximum rating.
 - See "Bypass Valve Kit (# STK0135)" on page 28.
 - For additional guidance testing water flow rates, please contact AquaCal®.
- A safety enhancing "Over Temperature Alarm" kit is strongly recommended for all spa applications. See "Over Temperature Alarm Kit" on page 29.

1.4.b Plumbing Diagrams

Plumbing diagrams are provided in this section as a planning guide to the sequence of equipment, valves, and fittings.

- The basic plumbing configurations for typical installations are shown.
- If the installation does not closely follow any of the supplied plumbing diagrams, AquaCal® Technical Support is available for installation advice and guidance.
- Confirm water provided to heat pump is clean and filtered.

Heat Pump with water flows equal or less than maximum listed flow rate

See "Water Flow Rates" on page 10.

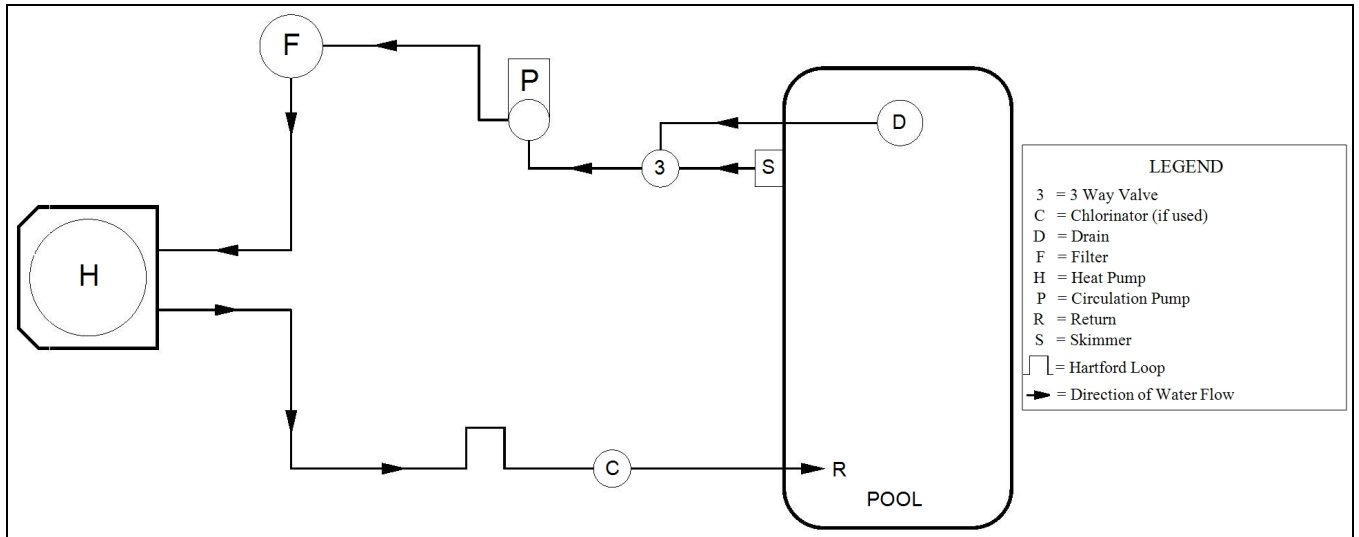

Heat Pump with water flows greater than maximum listed flow rate

See "Water Flow Rates" on page 10.

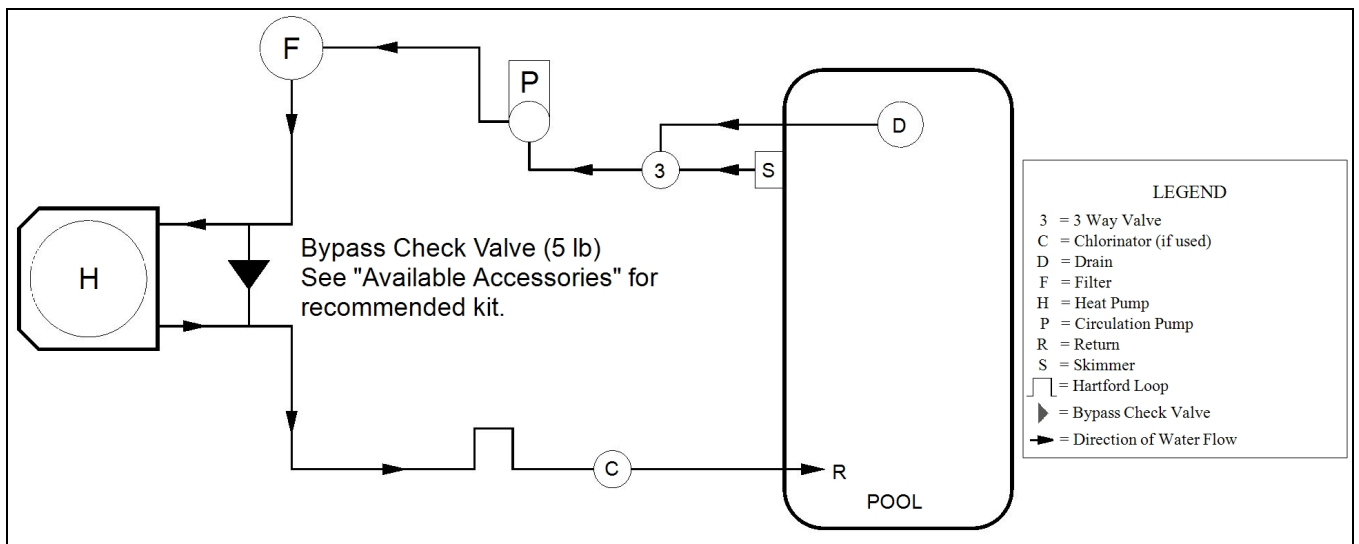

Heat Pump with Spillover Spa (One filter Pump)

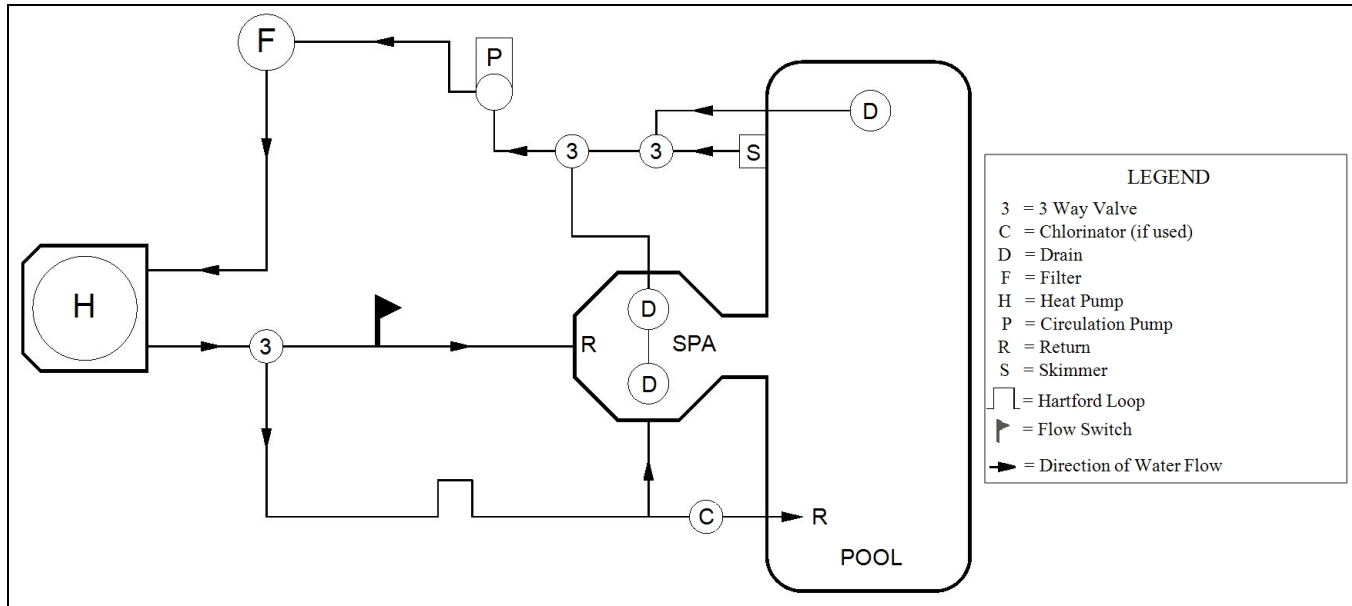

Heat Pump with Spillover Spa (Two filter Pumps)

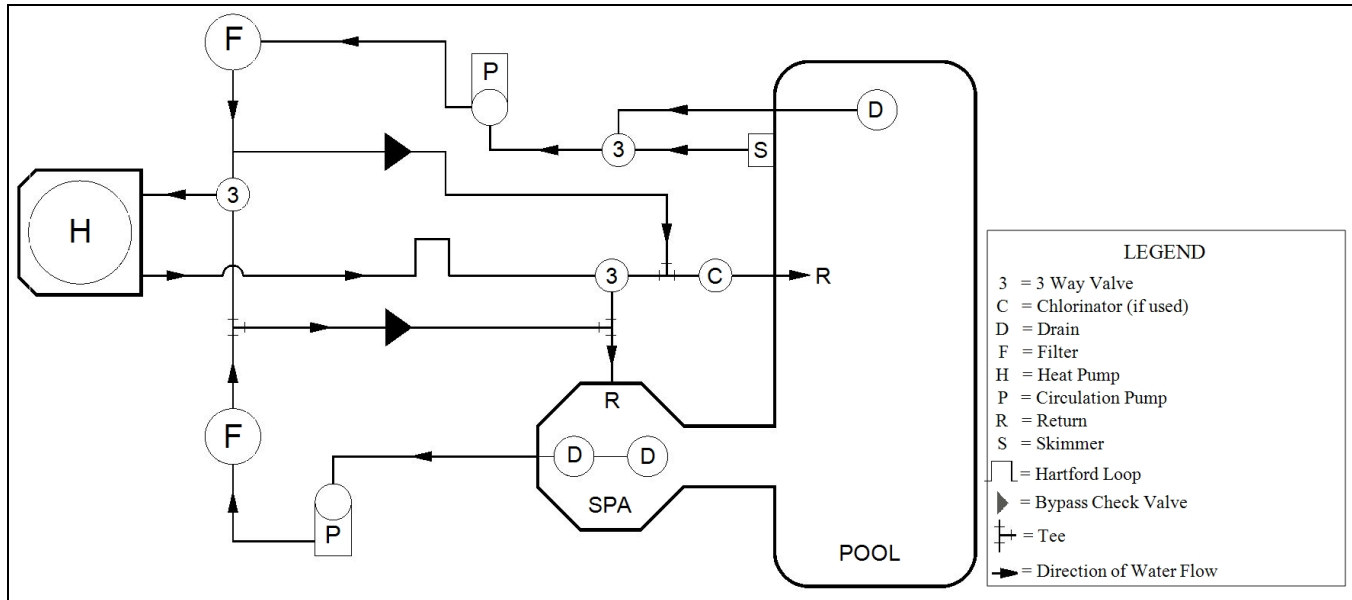

Heat Pump with Solar Panels in Plumbing Circuit

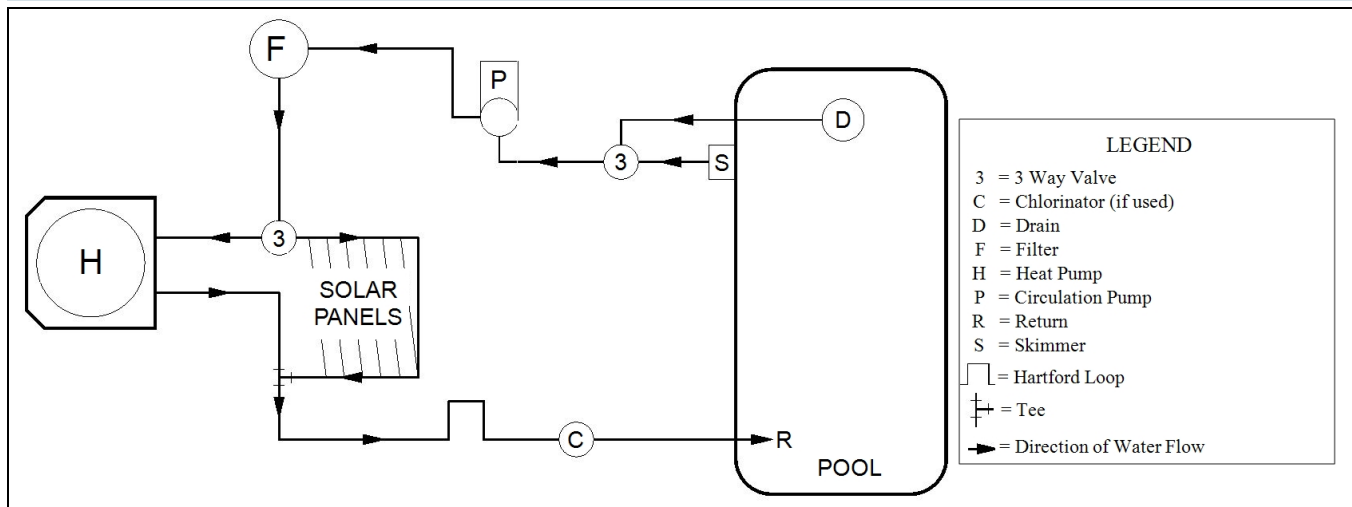

Heat Pump with Gas Heater backup

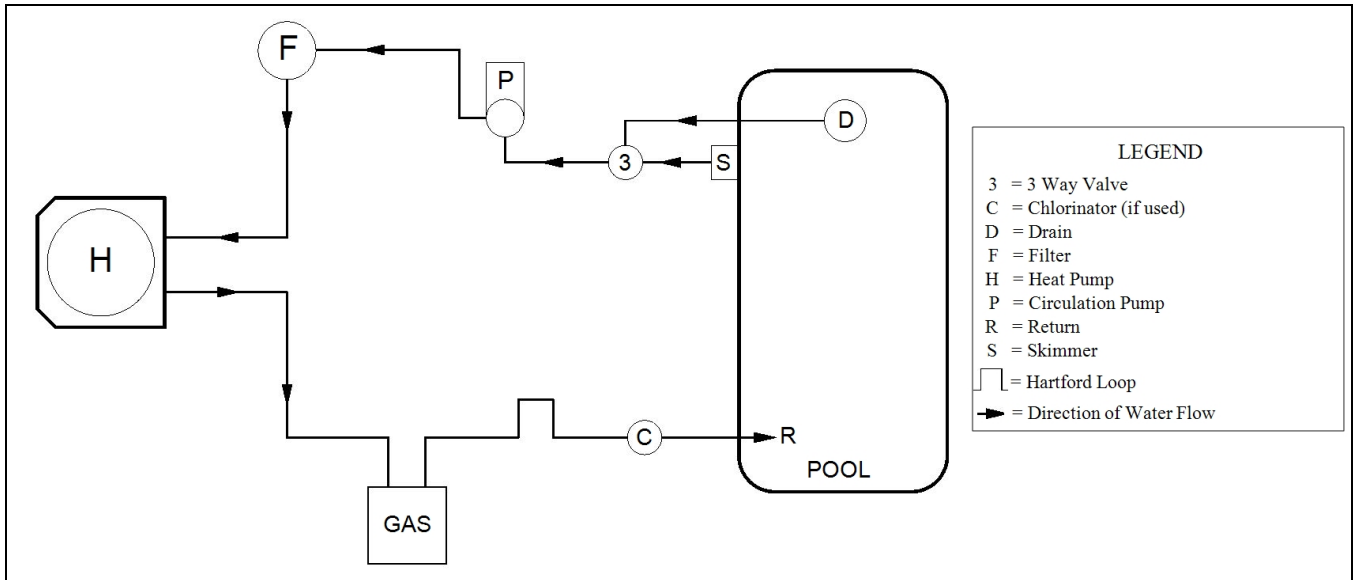

Multiple Air Source Heat Pumps

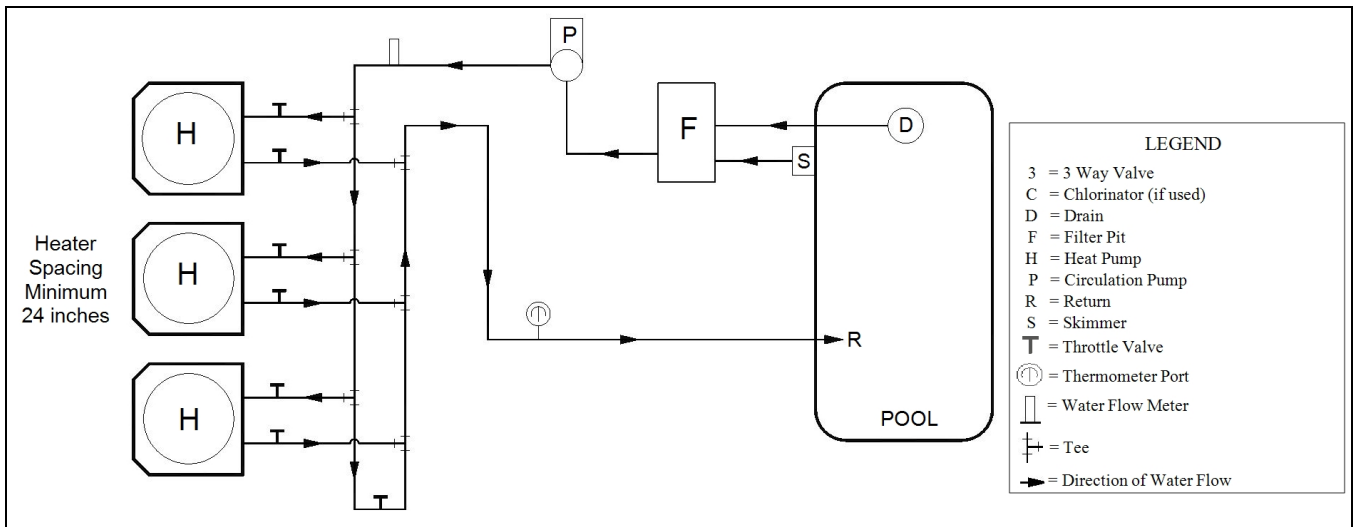

1.4.c Water Connections to Heat Pump

- Heat Pump union sizes are specified on diagrams.
- Connections to site plumbing are made via PVC solvent cement to the female slip socket of the plumbing unions.
- Plumbing unions are available from AquaCal®.

NOTICE

Failure to heed the following may result in damage to equipment.

- Do not use glue on the threaded portion of the equipment's unions. A glued-in-place union will prevent the equipment from being properly winterized.

HeatWave SuperQuiet® SQ120R, SQ125, SQ145, SQ166R, SQ225

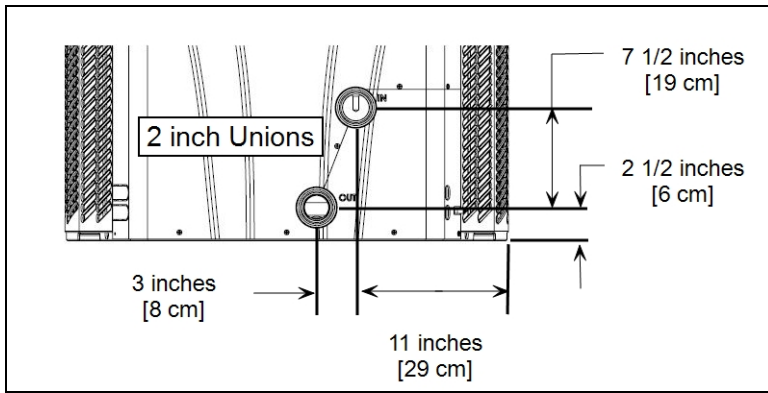

TropiCal® T035, T055, T075

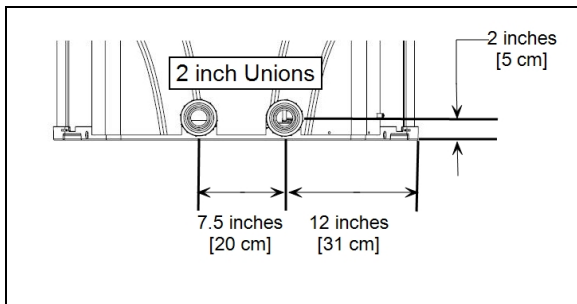

TropiCal® T090, T115, T135

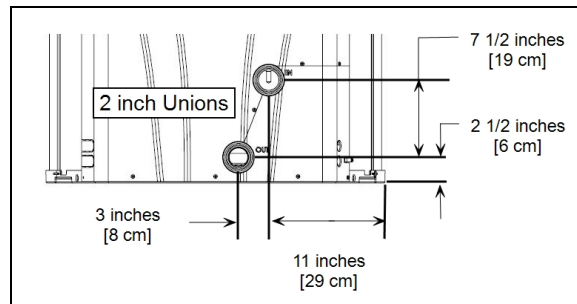

1.4.d In-Line Chlorine Feeders

Place in-line chlorinators downstream from the heat pump and as low in elevation as possible.

- If an erosion type feeder is used, it is recommended that a Hartford Loop be installed to protect internal heat pump components.
- A Hartford Loop is not necessary with a Salt Chlorine Generator.

Heat Pump with Hartford Loop

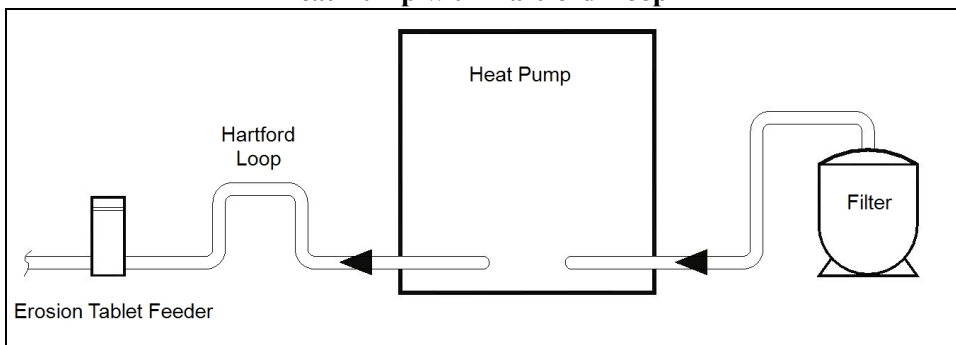

1.4.e Water Flow Rates

Maintain water flow rates as indicated. Please note, these specifications relate to the heat pump only. Code-specified whole system turnover rates must be satisfied.

NOTICE

Failure to heed the following may result in damage to equipment.

- Water flow exceeding maximum flow rates will negatively affect the total pool filtration performance and may damage the heat pump. This will not be covered under equipment warranty.

MODEL	HEAT EXCHANGER TYPE	FLOW RATES	
		MINIMUM	MAXIMUM
SQ120R	Titanium ThermoLink [®]	30 GPM	70 GPM
SQ125	Titanium ThermoLink [®]	30 GPM	70 GPM
SQ145	Titanium ThermoLink [®]	30 GPM	70 GPM
SQ166R	Titanium ThermoLink [®]	30 GPM	70 GPM
SQ225	Titanium ThermoLink [®]	30 GPM	70 GPM
T035	Titanium Tube-in-Tube	20 GPM	45 GPM
T055	Titanium Tube-in-Tube	20 GPM	45 GPM
T075	Titanium Tube-in-Tube	20 GPM	45 GPM
T090	Titanium ThermoLink [®]	30 GPM	70 GPM
T115	Titanium ThermoLink [®]	30 GPM	70 GPM
T135	Titanium ThermoLink [®]	30 GPM	70 GPM

PLEASE NOTE -

If minimum flow rates are not met, heat pump performance is reduced and performance will suffer. Internal safety devices may deactivate the heat pump with the following errors:

- *HP* and *HP5*
 - or (if equipped) error codes of *LP* and *LP5*
- Operate water filtration devices per manufacturer's specifications. Dirty filters can cause a reduction of water flow to the heat pump. An increase of 7-10 psi higher than the clean filter pressure typically reduces flow rates. This requires the filter to be cleaned or back-washed.
 - Keep baskets free of debris. A large quantity of debris in the pump and skimmer baskets can reduce water flow.
 - Check for improper valve settings. A partially closed valve after the filter, or a full-open bypass around the heat pump, will cause insufficient water flow through the heat pump.
 - The maximum static pressure (or operating pressure) is 50 pounds-per-square-inch (PSI). These specifications relate to the heat pump only.
 - Code-specified whole system turnover rates must be satisfied.

1.4.f Adjusting Water Flow Using ΔT (Delta-T)

The Delta-T is the temperature difference between the water temperatures entering and leaving the heat pump. The equipment can be fine-tuned for maximum performance by balancing water flow rates to maintain an ideal ΔT .

- Installed temperature ports are required to perform the following procedures.
- These ports are typically located on the pool in and pool out water lines approximately six inches away from the heat pump.
- **The adjustment procedure must be completed with the unit in heating mode.**

PLEASE NOTE -

- The installation of temperature ports are required for all commercial applications.
- The installation of temperature ports are strongly recommended for residential installations.
 - See "Temperature Port Kit (# STK0096)" on page 30.

1. Adjust thermostat to its lowest setting with unit in heating mode.
2. Deactivate the water filtration pump.
3. Confirm that the filters leading to the heat pump are clean.
4. Adjust the valves controlling water headed towards the heat pump to the half open position.
5. Adjust the valves controlling water leading away from the heat pump to a fully open position.
6. Activate the pool water filtration pump.
7. Slowly raise the thermostat temperature until the heat pump activates.
 - After a four-minute delay, the heat pump's compressor will start.
8. With the heat pump running, confirm water filtration pump is operating properly with adequate flow and no short cycling.
9. Wait for water temperatures to stabilize (approximately 5 minutes).
10. Adjust valves in the following order using the temperature chart provided:
 - a. Adjust the valve that controls water exiting the heat pump. Match the temperature measured with a temperature probe to the chart.
 - b. Wait for water temperatures to stabilize. Then check temperature again. Re-adjust the valve as needed.
11. Mark valves at these positions for future reference.

**Temperature Port
(Shown with Probe)**



MODEL	TEMPERATURE
SQ120R	3° to 7° F
SQ125	3° to 7° F
SQ145	3° to 7° F
SQ166R	3° to 8° F
SQ225	4° to 9° F

MODEL	TEMPERATURE
T035	1° to 4° F
T055	2° to 5° F
T075	3° to 7° F
T090	3° to 6° F
T115	3° to 7° F
T135	4° to 8° F

Table 1 - Temperature Chart

PLEASE NOTE -

- Temperature differences are based on pool water temperatures of 69° to 75° F.
- For water temperatures outside this range, contact AquaCal®. See "Contacting AquaCal AutoPilot, Inc." on page 1.

1.4.g Maintaining Ability to Winterize

Do not glue the threaded portion of the unions. The unions are used to decouple the heat pump from the plumbing system during hard freeze conditions.

NOTICE

Failure to heed the following may result in damage to equipment.

- Do not use glue on the threaded portion of the equipment's unions. A glued-in-place union will prevent the heat pump from being properly winterized.

1.4.h Adjusting Water Pressure Switch

Adjust water pressure switch when heat pump attempts to operate without water flow.

Before attempting any adjustments confirm the following :

- The filter is clean.
- Filter pump is operating.
- The valves are set to direct the appropriate amount of water through the heat pump. See "Water Flow Rates" on page 10.
- **FLO** is displayed (or displays intermittently).

WARNING

Failure to heed the following may result in injury or death.

- Water Pressure Switch adjustment procedure to be performed by experienced service personnel only; procedure must not be attempted by individuals lacking adequate electrical and mechanical experience.

NOTICE

Failure to heed the following may result in damage to equipment.

- If the heat pump continues to operate after a water pressure switch adjustment, deactivate equipment and perform additional troubleshooting.

1. Remove heat pump access panel.
2. Locate the water pressure switch. It will be outside and along the bottom edge of the electrical enclosure. Exact location varies by model.
3. Activate filter pump.
4. Apply power to heat pump.
5. Slowly rotate the adjustment wheel on the switch. Keep turning the wheel until the heat pump indicates it is receiving water. The display will no longer display the **FLO** code.
6. Deactivate filter pump. If correctly adjusted, the heat pump will deactivate and the display will show the **FLO** code.
7. Re-install heat pump access panel.
8. If the heat pump continues to operate without water flow, the installation of a grid flow switch may be required.
 - This can become necessary if the heat pump is installed below the elevation of the body of water to be heated or cooled. The standing pressure from the water can cause the water pressure switch to activate when the circulation pump is off. Therefore a water flow switch must be used in place of a water pressure switch to determine if incoming water is being sent to the heat pump. See "Grid Flow Switch (# 0040S)" on page 29.
9. If heat pump continues to operate without water flow, contact AquaCal®.

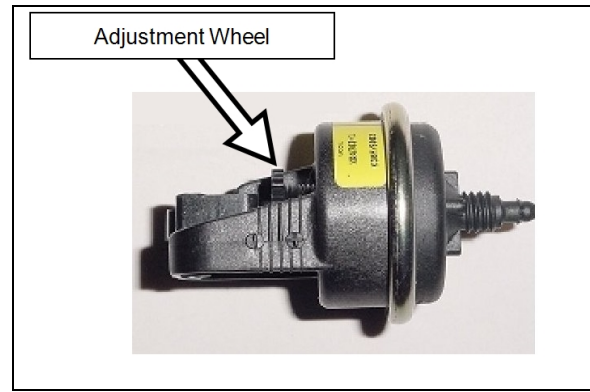

1.5 Electrical

1.5.a Electrical Requirements



Failure to heed the following may result in injury or death.

- The information contained in this section is intended for use by qualified electricians familiar with electrical service-industry safety standards and methods.
- Locate the equipment disconnect as near to the heat pump as possible. Always satisfy applicable codes and standards.
- Never mount power-disconnects directly to the heat pump.
- In sizing power wiring, be especially aware of up-sizing requirements necessary due to wiring distances. Always satisfy applicable codes and standards.
- AquaCal® heat pumps are designed to use copper conductors, only. Do not use aluminum wire.
- Multiple heat pumps installed at the same site may benefit from automatic sequencing controllers (ASC) to avoid excessive power drops at start-up. See "Available Accessories" on page 28.

Electrical Standards

Standards	Title
NFPA 70	The electrical installation must conform to the current version of the NEC, and all applicable local and state codes
NFPA 70 Article 440	Standard for Safety for Electric Spas, Equipment Assemblies, and Associated Equipment
NFPA 70 Article 680	Standard for Safety for Swimming Pool Pumps, Filters, and Chlorinators
IEC 60335-1-2001	Household and similar electrical appliances - Safety - General Requirements
IEC 60335-2-40 2006	Household and similar electrical appliances - Safety – Particular requirements for electrical heat pumps, air-conditioners, and dehumidifiers
UL1995 & CSA C22.2 236-05	Heating and cooling equipment

Table 2 - Standards

Grounding and Bonding

Follow local code requirements for properly grounding and bonding heat pump equipment.

- A bonding lug has been provided on the lower right hand corner of the front access panel.

Surge Suppression

The use of approved commercial surge protectors is strongly recommended.

Sizing the Electrical Service

Refer to equipment data plate for specific information required to size electrical service and over-current protection of heat pump. Sizing is based on data plate information, wire size, wiring devices, and over-current protection per applicable local codes and standards. See "Identifying Model Specifications" on page 26.

Minimum and Maximum Operating Voltage

The heat pump must operate within specified voltages.

NOTICE

Failure to heed the following may result in damage to equipment.

- Operating equipment under higher or lower voltage conditions may result in damage to your compressor, motors or other electrical components. This damage will not be covered by product warranty.
1. Measure site voltage. The site voltage **MUST** be measured under “FULL LOAD” conditions. Activate all equipment using the same electrical panel as the heat pump.
 2. If measured site voltage is outside listed ranges, immediately deactivate equipment until site conditions have been corrected. If unsure of heat pump equipment rating, please see "Identifying Model Specifications" on page 26.

Equipment Rating	Minimum Site Voltage	Maximum Site Voltage
A Voltage (208 to 230 Volts) Single Phase 60 hertz	200 Volts	253 Volts
B Voltage (208 to 230 Volts) Three Phase 60 hertz	200 Volts	253 Volts
D Voltage (380 to 420 Volts) Three Phase 50 hertz	361 Volts	441 Volts
E Voltage (380 Volts) Three Phase 60 hertz	361 Volts	399 Volts
G Voltage (460 Volts) Three Phase 60 hertz	437 Volts	483 Volts
H Voltage (200 to 240 Volts) Single Phase 50 hertz	180 Volts	264 Volts

1.5.b Incoming Power Access Holes

**(HeatWave SuperQuiet®
SQ120R, SQ125, SQ145,
SQ166R and SQ225)**

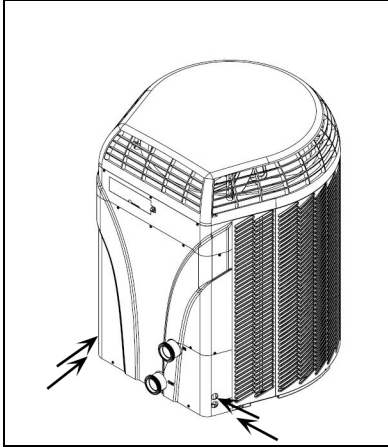

**(TropiCal® T035, T055
and T075)**

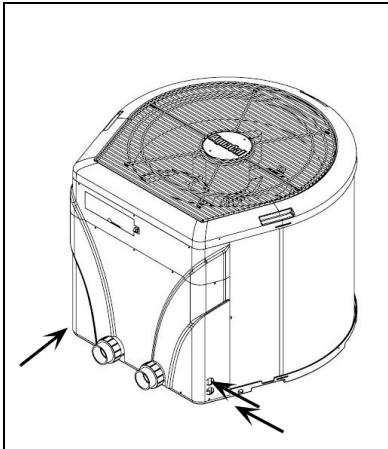

**(TropiCal® T090, T115
and T135)**

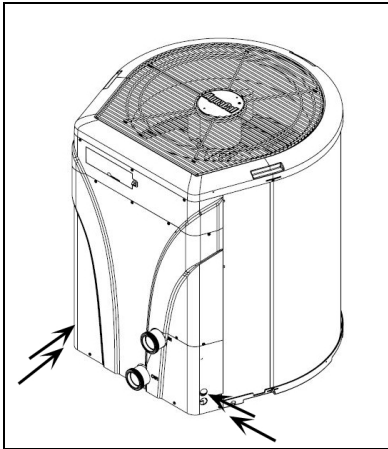

1.5.c Access Panels

HeatWave SuperQuiet®

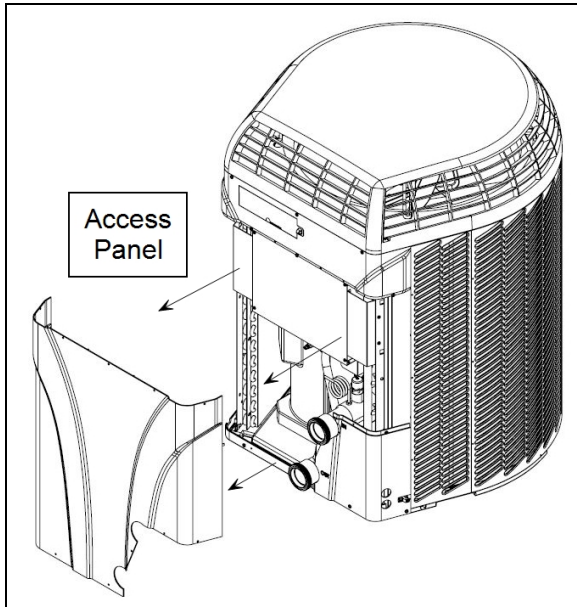

TropiCal®

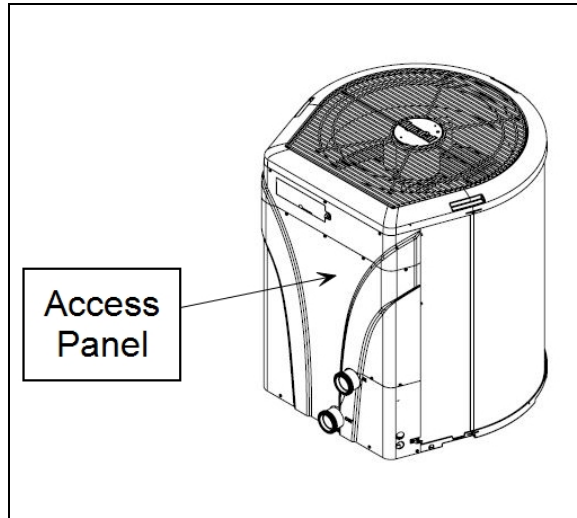

1.5.d Verifying Transformer Setting

Transformer voltage must be confirmed and set correctly depending on the measured voltage found on the site. Incorrect settings may cause heat pump damage. The following procedure will allow the installer to set the heat pump's transformer for the appropriate site voltage.



WARNING

Failure to heed the following may result in injury or death.

- The information contained in this section is intended for use by qualified technicians, familiar with electrical service-industry safety standards and methods.
1. Turn heat pump on by adjusting the thermostat to call for heating or cooling. If more than one heat pump is on site, turn them all on. Allow time for all heat pump compressors to activate.
 2. Measure the running site voltage.
 3. Confirm transformer tap is set for the measured site voltage. If more than one voltage tap is shown, select the voltage nearest to the running site voltage.

Example of heat pump transformer (Varies between models)

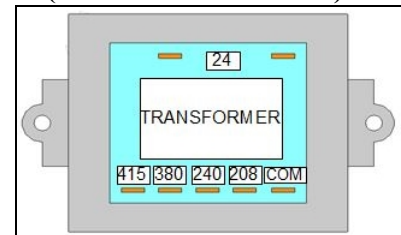

PLEASE NOTE -

- If more than one voltage is shown on the equipment's data plate, the factory default setting is usually the higher voltage on the transformer.
- As an example, a "208/230" voltage will be set to "240" from the factory.

1.5.e Three-Phase Adjustment



WARNING

Failure to heed the following may result in injury or death.

- The information contained in this section is intended for use by qualified technicians, familiar with electrical service-industry safety standards and methods.

If a three-phase unit fails to operate at start up, the orientation of the line voltage "field" wiring may need to be adjusted.

- The phase monitor is located inside the electrical panel.
1. Deactivate power to the unit. **Confirm that power is off to all three legs using an electrical test meter set for the correct voltage.**
 2. Switch position of the incoming power wires at each leg as follows, re-connect power, and attempt to restart the unit. If the unit fails to start, disconnect power. Verify off and proceed to next leg.
 - Switch incoming power wires at L1 and L2 on the line side to the contactor.
 - Switch incoming power wires at L1 and L3 on the line side to the contactor.
 - Switch incoming power wires at L2 and L3 on the line side to the contactor.
 3. When heat pump starts, disconnect power and verify off. Then confirm all line voltage connections are securely tightened. Reconnect power.
 - If heat pump does not start, contact AquaCal® for further assistance. See "Contacting AquaCal AutoPilot, Inc." on page 1.

Three-Phase Monitor



1.5.f Schematics

Schematics are located on the inside of the equipment access panel.

PLEASE NOTE:

- Specifications are subject to change without notice.
- Schematics are available by calling AquaCal® Customer Support. See "Contacting AquaCal AutoPilot, Inc." on page 1.
 - Please have the complete model and serial number available.
 - See "Identifying Model Specifications" on page 26.

1.5.g Connecting an External Controller

To support a direct connection to an external controller, AquaCal® heat pumps are equipped with optional terminal blocks. These terminals are on the microprocessor located on the low-voltage side of the electrical enclosure.



WARNING

Failure to heed the following may result in injury or death.

- This section is only for qualified installers who are familiar with swimming pool and spa safety standards.
- The installer must be familiar with service industry techniques.
- Deactivate power while routing wiring to control board.

NOTICE

Failure to heed the following may result in damage to equipment.

- The wire size connecting the controller must be 16-gauge, 2-conductor or larger, low-voltage wire.
- Use direct connection (**dry contact**) provided on the microprocessor for external controllers.

Please confirm the type of external controller to be installed and follow the appropriate instructions.

- A **two-wire** controller (**with an internal thermostat**). *The user can set and adjust the temperature at the controller's screen.*
- A **three-wire** controller (**with an "OFF" position**). *The user adjusts the temperature at the heat pump. The user can select pool or spa mode or turn off the heat pump using the controller.*
- A **three-wire** controller (**without an "OFF" position**). *The user adjusts the temperature at the heat pump. The user can select pool or spa mode, but must turn off the heat pump at the heat pump display panel.*

Dry Contact Connection Points to the Microprocessor

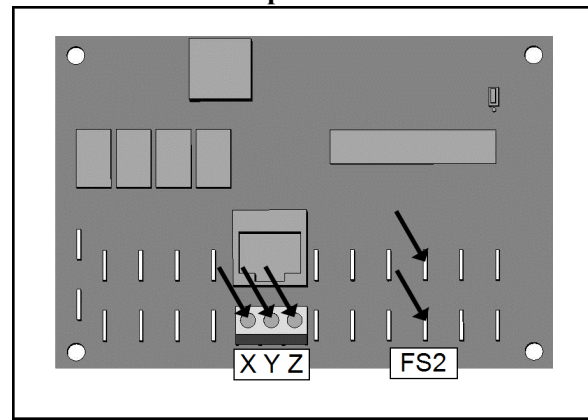

Two-wire controller (with internal thermostat):

1. Deactivate power to heat pump.
2. Remove heat pump electrical access panel.
3. Route the control wiring to the low voltage side of the electrical enclosure. Follow all National Electric Codes (NEC) unless State or Local guidelines supersede.
4. Connect the controller wires to the microprocessor as follows:
 - Connect one wire to "Y".
 - Connect other wire to "Z".
 - The polarity of the wire is not important.
5. Reattach heat pump access panel.
6. Apply power to heat pump.
7. Program heat pump for a two-wire controller. See "Using JAO interface" on page 20.

Three-wire controller (with "OFF" position):

1. Deactivate power to heat pump.
2. Remove heat pump electrical access panel.
3. Route the control wiring to the low voltage side of the electrical enclosure. Follow all National Electric Codes (NEC) unless State or Local guidelines supersede.
4. Connect the controller wires to the microprocessor as follows:
 - Connect "Low" or "Pool" wire to "X".
 - Connect "High" or "Spa" wire to "Z".
 - Connect "Common" wire to "Y".
5. Reattach heat pump access panel.
6. Apply power to heat pump.
7. Program heat pump for a three-wire controller. See "Using JAO interface" on page 20.

Three-wire controller (without an "OFF" position):

1. Deactivate power to heat pump.
2. Remove heat pump electrical access panel.
3. Route the control wiring to the low voltage side of the electrical enclosure. Follow all National Electric Codes (NEC) unless State or Local guidelines supersede.
4. Connect the controller wires to the microprocessor as follows:
 - Connect "Common" wire to one terminal of "FS2".
 - Connect "Spa" to other terminal of "FS2".
 - The third wire is not used.
5. Reattach heat pump access panel.
6. Apply power to heat pump.
7. Program heat pump for an external controller. See "Using FS2 interface" on page 21.

1.5.h Programming for an External Controller

Configure heat pump for external control.

Using JAD interface



Press "Up" and "Down" buttons simultaneously until **CF 1** appears.



Press "Pool / Spa" button until **LOC** is displayed.

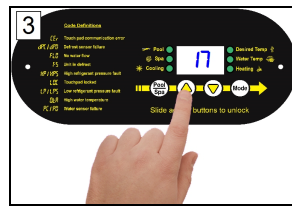

Press "Up" or "Down" to passcode. Default is "17".



Press "Pool / Spa" button once.

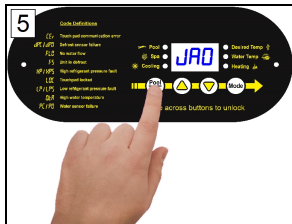

Press the "Pool / Spa" button until **JAD** is displayed.

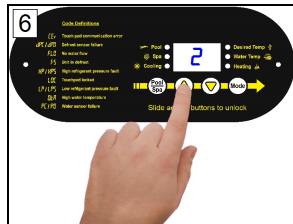

Press "Up" or "Down" button.

- "0" - none
- "2" - two-wire
- "3" - three-wire

Using F52 interface



Press "Up" and "Down" buttons simultaneously until **CFI** appears.



Press "Pool / Spa" button until **LOC** is displayed.

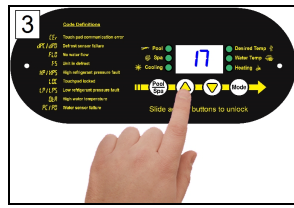

Press "Up" or "Down" to passcode. Default is "17".



Press "Pool / Spa" button once.

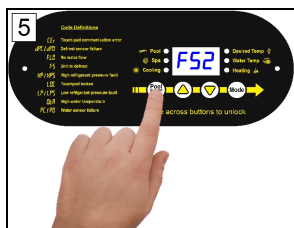

Press the "Pool / Spa" button until **F52** is displayed.

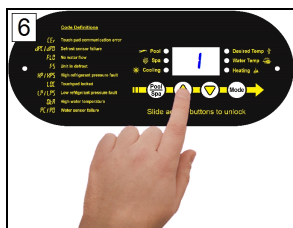

Press "Up" or "Down" button.

- "0" - none
- "1" - External

1.6 Service Level Programming

NOTICE

Failure to heed the following may result in damage to equipment.

- Service Level Programming must only be attempted by authorized personnel.
- Unauthorized adjustments in the Service Menu (beyond the **LOC** menu) may void the heat pump's warranty.
- Resetting the microprocessor to access a locked keypad will reset all settings to factory default including any installer-entered configuration. Re-programming all custom site condition settings will be required when using this reset.
- For further assistance, please see *"Contacting AquaCal AutoPilot, Inc." on page 1.*

PLEASE NOTE -

Before changing multiple program options, it is recommended that the user lock option be disabled.

The lockout option can be re-enabled after all changes are completed.

1.6.a Service Level Factory Defaults

Certain programming options have been preset at the factory. These options can be overwritten for certain site-specific conditions.

Table 3 - Default Program Parameters Chart

Code	Description	Default Value	Range
<i>CFD</i>	Call-Flex Options	0	Set to off at the factory.
<i>dbP</i>	Pool Dead-Band Differential	1°	Set at factory. Do not adjust.
<i>dbS</i>	Spa Dead-Band Differential	1°	Set at factory. Do not adjust.
<i>dEL</i>	Compressor Time Delay	1 (4 minutes)	Set to on (at 4 minutes) at the factory. Do not adjust.
<i>dSC</i>	Defrost Sensor	Factory Calibrated	Set at factory. Do not adjust.
<i>dFd</i>	Defrost Delay	Factory Calibrated	Set at factory. Do not adjust.
<i>F52</i>	Flow Switch / Automatic Thermostat Switching Option	0	0 = "No Switch" 1 = "Enable Switch"
<i>JAD</i>	External Controller	0	0 = "No Controller" 2 = "Two Wire Controller" 3 = "Three Wire Controller"
<i>LDC</i>	Service Level Entry Point	50	00 - 99
<i>tSC</i>	Water Sensor	Factory Calibrated	Set at factory. Do not adjust.

1.6.b Enter Service Level Programming

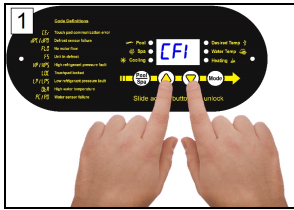

Press "Up" and "Down" buttons simultaneously until **CF 1** appears.



Press "Pool / Spa" button until **LOC** is displayed.

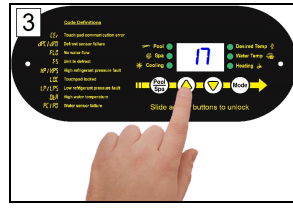

Press "Up" or "Down" to passcode. Default is "17".



Press "Pool / Spa" button once.

Programming for a Relay Switch

Configure heat pump for a relay or flow switch. This can provide automatic pool/ spa thermostat switching.

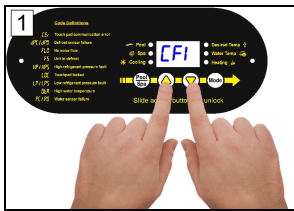

Press "Up" and "Down" buttons simultaneously until **CF 1** appears.



Press "Pool / Spa" button until **LOC** is displayed.

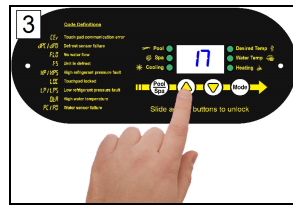

Press "Up" or "Down" to passcode. Default is "17".



Press "Pool / Spa" button once.



Press the "Pool / Spa" button until **F52** is displayed.

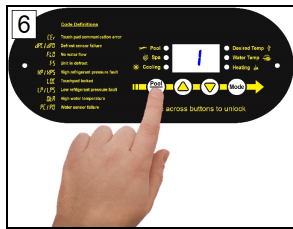

Press the "Up" or "Down"

- "0" - not active
- "1" - enable

PLEASE NOTE -

Once the **F52** feature has been activated the "POOL / SPA" button will no longer function. The relay or flow switch is used to change between the pool and spa temperature settings.

Reset to Factory Defaults Settings

NOTICE

Failure to heed the following may result in damage to equipment.

- Using this option will reset **ALL** settings to their factory defaults including external controller settings and sensor calibrations. **DO NOT** perform this operation if unsure of site specific settings or how to reset them on the heat pump.
- If a qualified technician is unavailable, please see *"Contacting AquaCal AutoPilot, Inc."* on page 1.

1. Simultaneously Press "Pool / Spa" button and "Up" button until the display shows **888**.
2. Release buttons. Reset is complete.



1.7 Cleaning Equipment After Installation

Installer - If you need to clean equipment after installation, please use the following guidelines.

WARNING

Failure to heed the following may result in injury or death.

- Possible electric shock hazard - Deactivate power to all electrical devices on the pad when washing heat pump. Do not restore electrical power until equipment is completely dry.

NOTICE

Failure to heed the following may result in damage to equipment.

- Do not use a pressure cleaner to wash heat pump. Damage to heat pump components may result. If using a hose-end spray nozzle adjust spray pattern to low strength only.
- Do not spray water directly into the interior of the heat pump; damage to components may result.
- Do not use chemicals on the display panel.

Cleaning

1. Wash outside cabinet using a low-pressure water hose. A high-pressure water stream will cause damage to the aluminum fins of the heat pump. This damage is not covered under product warranty.
2. While the heat pump is still wet, use an approved cleaning agent to clean the exterior of the heat pump. **Do not use chemicals on the display panel.**
3. Use a detergent-dampened cloth to wipe the heat pump's exterior cabinet.
4. Flush all exterior with fresh water using a low-pressure water hose.
5. Dry the exterior cabinet using a soft cloth being careful not to damage evaporator fins.

APPROVED CLEANING AGENTS*

Fantastic®

Formula 409®

Cascade®

All Power Plain Detergent (3% Solution)

Table 4 - Cleaning Agents

Polishing

1. Polish the heat pump's cabinet panels using an approved polishing agent and following the manufacturer's instructions. Do not use chemicals on the display panel.
2. Rinse the heat pump panels with fresh water, wipe, and buff panels using a dry soft cloth.
3. Allow heat pump interior and surrounding equipment to "air-dry" for several hours prior to restoring electrical power.

APPROVED POLISHING AGENTS*
Simoniz® Wax
Glo-Coat®
Aarmor All® Protectant

Table 5 - Polishing Agents

- * The trademarks used in approved cleaning and polishing agents are property of their owners and are not related to AquaCal®.

2 - Appendix

2.1 Identifying Model Specifications

1. Find Data Plate - The data plate is usually posted on the side of the equipment or the inside of the heat pump's access plate.
2. Find the model number on the data plate. The first letters and numbers indicate the model type.
3. The complete model number identifies the equipment's specifications.

Data Plate Example

MINIMUM CIRCUIT AMPACITY	<input type="text"/>	MADE IN THE USA
ELEC. SERVICE: VOLTS	<input type="text"/>	PH <input type="text"/> HZ <input type="text"/>
MAXIMUM TIME DELAY FUSE OR HACR BREAKER	<input type="text"/> 5	
COMPRESSOR VOLTS	R.L.A. <input type="text"/>	L.R.A. <input type="text"/>
FAN MOTOR VOLTS	H.P. <input type="text"/>	F.L.A. <input type="text"/>
REFRIGERANT: Circuit - Factory charged	<input type="checkbox"/>	Only oz/Kg <input type="text"/>
Tested to	<input type="checkbox"/> psig High side /	<input type="checkbox"/> psig Low side
OUTDOOR USE		
AQUA CAL, INC A TEAM HORNER COMPANY 2737 24 TH STREET NORTH ST. PETERSBURG, FL 33713 FACTORY SERVICE 727-523-5642		MODEL NUMBER <input type="text"/> IIIBAR CODEIII SERIAL NUMBER <input type="text"/> IIIBAR CODEIII

Model Number Example

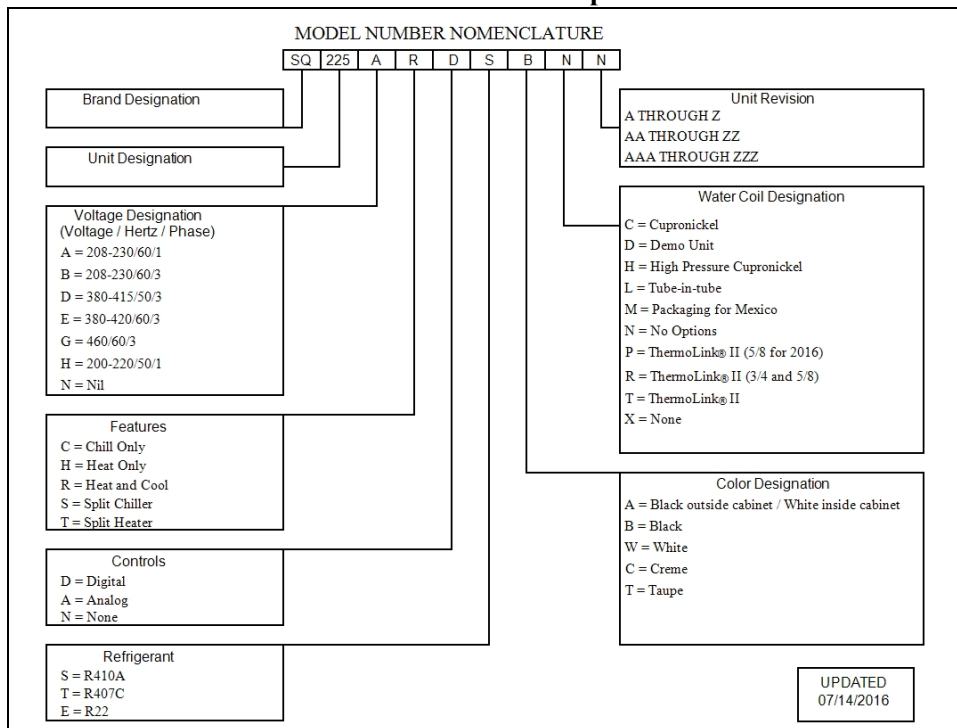

2.2 Weights

NOTE:

Specifications subject to change.

Model Type	Model Number	Install Weight
TropiCal®	T035	180 Pounds
TropiCal®	T055	180 Pounds
TropiCal®	T075	200 Pounds
TropiCal®	T090	255 Pounds
TropiCal®	T115	259 Pounds
TropiCal®	T135	287 Pounds
HeatWave SuperQuiet®	SQ120R	268 Pounds
HeatWave SuperQuiet®	SQ125	268 Pounds
HeatWave SuperQuiet®	SQ145	328 Pounds
HeatWave SuperQuiet®	SQ166R	328 Pounds
HeatWave SuperQuiet®	SQ225	328 Pounds

Table 6 - Equipment Weight

2.3 Heating Recommendations

The following recommendations will reduce the amount of time required to heat a pool. **If unsure of equipment heating capability, review equipment data plate.** See "Identifying Model Specifications" on page 26.

1. Confirm heat pump mode has been set to heating mode.
2. Set a desired temperature (set point) for the water.
3. Temporarily set the filter pump for continuous operation.
 - This will allow the Heat Pump the time required to heat the water at start-up.
 - After the water has reached the desired temperature, reset the filter pump to normal operating time-frames.
4. Use a pool cover or blanket to reduce heating time.

2.4 Cooling Recommendations

The following recommendations will reduce the amount of time required to cool a pool or cold plunge application. **If unsure of equipment cooling capability, review equipment data plate.** See "Identifying Model Specifications" on page 26.

1. Confirm heat pump mode has been set to cooling mode.
2. Set thermostat to desired water temperature.
3. Temporarily set the filter pump for continuous operation.
 - This will allow the Heat Pump the time required to cool the water at start-up.
 - After the water has reached the desired temperature, reset the filter pump to normal operating time-frames.

2.5 Available Accessories

Accessories may be purchased through an authorized dealer of AquaCal® products.

Bypass Valve Kit (# STK0135)

- When high flow rates are outside recommended specifications, please use this kit or an alternative bypass valve system.
- This kit can be used to control excessive water flow through the heat pump. It provides automatic flow adjustments for most applications.



Condensation Drain Kit (# STK0202)

- Used when condensation water flow must be directed to a specific location.



Call Flex Accessory (# 0030-LEDS)

- This accessory will override a circulation pump to provide water to the heat pump when the set temperature is not met.

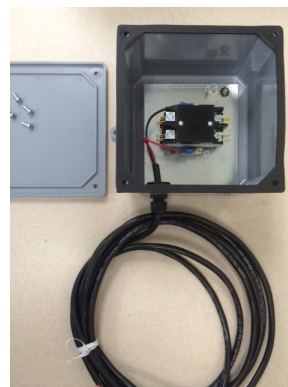

Automatic Sequencing Controller

- An Automatic Sequencing Controller (ASC) provides easy control of all units from one lead unit and prevents the simultaneous start-up of multiple heat pumps.
- Site voltage drop is minimized and utilities are not subjected to large in-rush demands of electrical current.
- Part number is based on number of heat pumps to be controlled. Call AquaCal® for assistance with correct configuration. See "Contacting AquaCal AutoPilot, Inc." on page 1.

Grid Flow Switch (# 0040S)

- Used for automatic pool / spa thermostat switching.
- This switch can also be used in place of the water pressure switch. This may be needed when the pool / spa elevation is higher than the heat pump. A higher elevation of the water can cause a false signal to the heat pump; indicating water is flowing through the heat pump when it isn't.
- This kit is not to be used on applications exceeding 50 PSI.



Liquid Blankets

- An invisible liquid heat barrier designed to retain heat and extend the swimming season.
- AquaCal® recommends [Lo-Chlor®](#) Aqua Blanket™.



Over Temperature Alarm Kit

- This kit is an additional safety device. It disables the heat pump if any malfunction occurs that allows the water temperature to surpass a safe level.
- This kit is strongly recommended for all spa applications.
 - Single Phase Heat Pump- (# STK0221)
 - Three Phase Heat Pump - (# STK0222)

Plumbing Unions

- 2 Inch Unions - (# PLS2627)



Remote Control Kit (STK0070)

- A remote (wired) control kit allows for full control of the heat pump from up to 100 feet from the equipment.

Temperature Port Kit (# STK0096)

- This port can be used to adjust water flow using Delta-T.
- The kit comes with port, installation components, and a temperature probe.



3 - Troubleshooting

3.1 Fault Codes

A fault code indicates a specific issue or condition that will require action before the equipment can resume operating.

Please perform the following troubleshooting.

If the issue reoccurs, please see "*Contacting AquaCal AutoPilot, Inc.*" on page 1.

WARNING

Failure to heed the following may result in injury or death.

- Repairs must not be attempted by untrained or unqualified individuals.
- The heat pump contains refrigerant under high pressure. Repairs to the refrigerant circuit must not be attempted by untrained or unqualified individuals. Service must be performed only by qualified HVAC technicians. Recover refrigerant before opening the system.

NOTICE

Failure to heed the following may result in damage to equipment.

- Service by unauthorized personnel will void the heat pump warranty.

FLO Indicator

ISSUE

Low or no water detected.

RESOLUTION

1. Confirm the filter pump is on.
2. If a multiple-speed filter pump is being used, run at a higher speed to determine if the error persists. Do not exceed maximum flow rate for your model.
3. Confirm water is not being diverted away from the heat pump.
 - See "Water Flow Rates" on page 10.
 - See "Adjusting Water Flow Using ΔT (Delta-T)" on page 11.

F5 Indicator

ISSUE

The heat pump has sensed the evaporator coil is icing up.

RESOLUTION

PASSIVE DEFROST - Heat Only

When ice starts to form on the coil, the compressor will stop operating while the fan continues to operate.

- When the coil's temperature rises above 38° F, the compressor is restarted and heating or cooling resumes.
- If the coil's temperature remains below 38° F, the compressor will remain off.

ACTIVE DEFROST - Reversing Units

When ice starts to form on the coil, the heat pump will stop heating or cooling the water for 10 minutes. Hot refrigerant gas will be sent through the coil to rapidly remove ice or frost. During this process, the melting of the ice may appear as steam coming off the heat pump. This is normal.

- After the 10 minute defrost cycle has expired, the heat pump will resume heating or cooling the water.
- If after 50 minutes, the heat pump senses the coil still has ice on it, the defrost cycle will resume.

CEr Indicator

ISSUE

This can indicate a loose or damaged communication cable.

RESOLUTION

A qualified technician should check the cable from control board to display assembly for a loose connection or visible damage.

CSE Indicator

ISSUE

This is a control system error.

RESOLUTION

Deactivate then reactivate power to reset controls.

dPC or dPD Indicator

ISSUE

Shorted or open defrost sensor.

RESOLUTION

A qualified technician should replace the defrost sensor.

PC or PD Indicator

ISSUE

Shorted or open water sensor.

RESOLUTION

A qualified technician should replace the water sensor.

HP Indicator

ISSUE

The refrigerant system's high-pressure switch is showing as open.

RESOLUTION

If the heat pump is a reversing unit, place it in **HEA** mode and perform the following troubleshooting.

Determine if an insufficient amount of water is being supplied to the equipment.

1. Confirm the filter pump is on.
2. If a multiple-speed filter pump is being used, run filter pump at a higher speed. Do not exceed maximum flow rate for the model.
3. Confirm water is not being diverted away from the heat pump.
 - See "Water Flow Rates" on page 10.
 - See "Adjusting Water Flow Using ΔT (Delta-T)" on page 11.
4. The water pressure switch may be incorrectly calibrated. See "Adjusting Water Pressure Switch" on page 12.

HP5 Indicator

ISSUE

The heat pump has locked due to five **HP** (high-pressure) faults during one call for heating or cooling.

RESOLUTION

1. Deactivate then reactivate power to the heat pump to clear error.
2. Troubleshoot the high-pressure issue causing the error. See "HP Indicator" on page 32.

LP Indicator

ISSUE

The refrigerant system's low-pressure switch is showing as open.

RESOLUTION

If the heat pump is a reversing unit, place it in **HEA** mode and perform the following troubleshooting.

1. Check for proper fan operation. If fan is not operating, contact AquaCal®.
2. Check for obstructed air flow around the heat pump.
 - See "Clearances" on page 4.
3. Check for dirty or blocked evaporator coil.
4. Check for signs of heavy ice buildup on the coil.

LP5 Indicator

ISSUE

The heat pump has locked due to five **LP** (low-pressure) faults during one call for heating or cooling.

RESOLUTION

1. Deactivate then reactivate power to the heat pump to clear error.
2. Troubleshoot the low-pressure issue causing the error. See "LP Indicator" on page 33.

OWA Indicator

ISSUE

Incoming water temperature exceeded 110° F and the unit is locked with an **OWA** over temperature alarm. The heat pump will not operate until incoming water temperature drops to 100° F or lower.

RESOLUTION

1. Determine if another heat source (gas heater, solar heater, etc.) is heating water being sent directly to the heat pump with the **OWA** indicator. This situation will need to be corrected before continuing.
2. Rule out an incorrect reading from the water temperature sensor. Verify existing water temperature with an accurate thermometer. If heat pump's sensor is inaccurate, the water temperature sensor may require replacement.

3.2 Issues and Resolutions

WARNING

Failure to heed the following may result in injury or death.

- Repairs must not be attempted by untrained or unqualified individuals.
- The heat pump contains refrigerant under pressure. Repairs to the refrigerant circuit must not be attempted by untrained or unqualified individuals. Service must be performed only by qualified HVAC technicians. Recover refrigerant before opening the system.

NOTICE

Failure to heed the following may result in damage to equipment.

- Service by unauthorized personnel will void the factory warranty.

Please perform the following troubleshooting.

For further assistance, please see "*Contacting AquaCal AutoPilot, Inc.*" on page 1.

Display Panel Not Responding

1. If the heat pump is controlled by an external controller, confirm the external controller settings.
2. If the issue is still occurring, disconnect external controller from the heat pump. Then check operation at heat pump.
 - If display panel responds, the problem lies with the external controller or its installation. Contact the manufacturer of the external control device.

Heat Pump Not Running

1. Confirm equipment is receiving power. Is the heat pump display illuminated?
 - If not, confirm the main breaker (located at the power supply panel) and the disconnect switch (located near the heat pump) are both turned on.
 - If the display still does not illuminate, it is recommended that the heat pump installer or electrician confirm heat pump is receiving power.
2. Confirm correct mode is selected.
3. Confirm thermostat is set correctly.
 - When heating the water is desired, the thermostat should be set above the current water temperature.
 - When cooling the water is desired, the thermostat should be set below the current water temperature.
4. If an error code is displayed, diagnose and correct the cause of the code. See "Fault Codes" on page 31.
5. If the heat pump is using an external controller, the heat pump may not be set correctly to accept the controller's signal.
 - See "Connecting an External Controller" on page 18.

Heat Pump's Tripping Breaker

1. Have an electrician confirm breakers are in good condition and properly sized for the heat pump.
2. Multiple heat pumps installed at the same site may benefit from special automatic sequencing controllers to avoid excessive power drops at start-up.
3. If a fault occurs immediately when the compressor starts, a qualified technician should evaluate the system.

Heat Pump Won't Shut Off

PLEASE NOTE

When heat pump is set to "OFF", the display will show either the water temperature or FLD.

1. Confirm the heat pump has reached the desired temperature set on the thermostat. The heat pump will continue to run until the set temperature is reached.
2. If the heat pump is using an external controller, it may not be set correctly.

Heat Pump Is Running, Not Heating

1. If the heat pump is using an external controller, confirm it is set correctly.
 - If the heat pump is still not running correctly with this device, contact the installer of the external controller device or the device's manufacturer for further assistance.
2. Confirm heat pump mode is set to **HEA** operating mode.
3. Confirm thermostat is set to the desired water temperature.
4. Confirm valves are correctly positioned to heat the correct body of water (either the pool or the spa). If heating a spa that overflows into a pool, confirm the spa is isolated when being heated (not flowing into the pool).
5. Confirm heat pump is transferring heat into the water.
 - Measure the temperature of air discharge coming out of the heat pump fan. If discharge air is between 8° to 10° colder than the outside ambient air, the heat pump is moving heat into the water.
6. If an error code is displayed, diagnose and correct cause of code. See "Fault Codes" on page 31.
7. Confirm that filter pump has a sufficient run-time. The heat pump will not run (or heat the water) without water flow. Heat Pump equipment will generally be set to run 24 hours a day in commercial applications.
8. If heating a spa, deactivate air blower or venturi (if equipped) to allow for quicker heating times. For pools, deactivate water features, such as slides, waterfalls, or fountains to allow water to retain heat. Use of a liquid pool blanket product can also compensate for excessive heat loss.
 - See Available Accessories on page 28 for more information on liquid blankets.

Heat Pump Is Running, Not Cooling (Reversing Models)

1. If the heat pump is using an external controller, confirm the heat pump is programmed properly to allow for cooling.
2. Confirm the heat pump mode is set to **COO** operating mode.
3. Confirm the thermostat is set below the current water temperature.
4. Confirm valves are correctly positioned to cool the correct body of water (either the pool or the spa). If cooling a spa that overflows into a pool, confirm the spa is isolated when being cooled (not flowing into the pool).
5. If an error code is displayed, determine and correct the condition causing the code. See "Fault Codes" on page 31.
6. Confirm heat pump is transferring heat out of the water.
 - Measure the temperature of air discharge coming out of heat pump's fan. If the air is between 8° to 10° warmer than the outside ambient air, the heat pump is moving heat out of the water.
7. Confirm that filter pump has a sufficient run-time. The heat pump will not run (or cool the water) without water flow. Heat Pump equipment will generally be set to run 24 hours a day in commercial applications.

Ice Forming on the Heat Pump

When conditions are too cold for proper operation, the heat pump will enter a defrost mode. This prevents ice from building up on the evaporator coil.

Heat Only Units:

- The heat pump may develop a fine layer of white frost on the outside coil before entering the defrost mode. This is normal.
- If heavy ice (not frost) starts to build up, shut off the heat pump. Contact the installer or manufacturer.
- If the ambient air temperature will be falling below 32° F for more than 8 hours, winterize equipment.

Heat and Cool Units (with Active Defrost or “Icebreaker”):

- During freezing conditions, pool or spa heating will continue. Frost or ice may develop during the “countdown” to the active defrost (up to 50 minutes). This is normal.
- The heat pump will enter an "active defrost" stage to remove the accumulated frost and ice.
 - During the active defrost period, the pool or spa will stop heating.
 - Observe the heat pump after its active defrost cycle. If ice or frost remains when the unit goes back to heating, deactivate the unit and call for service.
- If the ambient air temperature is (or will be) falling below 32° F for more than 8 hours, winterize equipment.

Water Coming From Heat Pump

The water may be normal condensation produced as a by-product of the heat pump's refrigeration process. The heat pump can produce 8 to 10 gallons of condensation per day depending on the humidity of the ambient air. Determine if the water is condensation or a possible leak.

1. Deactivate heat pump, leaving the filter pump on. After several hours, determine if water is still coming from the heat pump.
2. If using chlorine or bromine as a pool / spa sanitizer, test the water around the heat pump using a test strip. If the test strip indicates that chlorine or bromine is present, a leak may exist.

PLEASE NOTE -

If desired, a kit is available to re-direct condensation water away from the heat pump. See "Condensation Drain Kit (# STK0202)" on page 28.